



800-853-6625
www.blsports.com

1309 Raleigh Avenue
Norfolk VA 23507

PO Box 5329
High Point NC 27262

Credits/Damages/Return/Warranty Policy

Credits:

- If you need a credit for any reason call your sales representative. He will have his BLG sales manager or the accounting department issue a credit memo.
- Only BLG sales managers or the accounting department may authorize and issue credit memos.
- No credits will be given as payment deductions without posted credit memo – Do NOT pay your invoices short
- All products are shipped FOB from multiple factories. Please ensure your company's preferred shipper is completed on our set up form and any specific instructions are provided on your purchase order.

Incorrect/Refused Shipments:

- If part of your order is incorrect (ex. You receive Miami Dolphins product when you ordered University of Miami or you received 2 recliners when you ordered a recliner and a sofa).
 - Accept the parts of the order that are correct
 - Refuse only the pieces that you did not order and notate on the delivery receipt what piece(s) were refused and why
 - Contact your sales representative immediately to inform them of the problem.

Damages:

In order for Baseline and you, our customer, to receive credit for shipping damage we must file a claim within 72 hours of delivery. You must follow these procedures:

- Please inspect delivered products before accepting delivery
- If damage is recognized upon delivery:
 - Carrier Shipment – The BOL must be signed as damaged and product refused
 - Ground Shipments – Must be signed for as damaged and returned to shipper.
- If damage is discovered after delivery:
 - Retain original packaging.
 - BLG must be notified within 72 hours of delivery by contacting your sales representative who will fill out a damage report form. Sending digital pictures of damage is always helpful.
- Any repair to damages or defectives must be authorized before repair is made. We will work with our manufacturer partners to make a quick decision if it is a repair or replacement.
- Hidden defects discovered after delivery will be taken care of under Baseline's warranty policy.
- All parts request should be sent to the sales department's customer service specialist.

Returns and Cancellations:

- Returns will be accepted with a Return Authorization (non posted credit memo) issued by a sales manager or the accounting department.
- Cancellation of an order must be done in writing and acknowledgement received by a sales manager.
- Refusing a shipment except for visible physical damage may incur a 20% restocking fee plus all shipping charges.
- All items must be returned in original packaging.



800-853-6625
www.blssports.com

1309 Raleigh Avenue
Norfolk VA 23507

PO Box 5329
High Point NC 27262

Baseline contracts with quality manufacturers recognized as the best in the industry to produce the licensed products with which we supply you. We work closely with our manufacturers to ensure that products are of top quality but recognize that occasionally something may occur which is out of our control and will affect the quality of your product. For that reason we offer the following warranties on our product which are backed by the manufacturers.

UPHOLSTERED FURNITURE

Classic Sofa, Pub Sofa, Big Daddy Recliner, Home Team Recliner

LIMITED WARRANTY

Manufacturer Furniture offers a five year product warranty on all frames, and a one year warranty on all foam and manufacturing defects. This warranty is limited and does not account for normal wear and tear and abuse.

Manufacturer Furniture has a limited fabric warranty for all fabrics used in the manufacturing process of our upholstered furniture. This warranty is applicable for 30 days from the date of shipment to the retail store for obvious knitting defects (i.e. missing warps, slubs, runs, etc.). Manufacturer does not provide any warranty protection for any product that has been treated or sprayed with any after-market application (i.e. Stainsafe). Pilling and crocking are natural occurrences on polyester fabrics and are not a defect.

Kids Recliner, Video Chair, Ottomans

LIMITED WARRANTY

The wood frame parts and foam seat cores are warranted to be free of defects in materials and workmanship under our one (1) year limited warranty. This warranty will not cover damage caused by misuse or abuse. Only the actual loss of foam resiliency is covered by the warranty. The loss of resiliency should not be confused with normal softening that will occur in all foam as a result of use or aging. This warranty is limited to repair or replacement of the defective part.

All upholstery fabrics used by Manufacturer on furniture have a limited warranty for one (1) year from the original date of purchase against wear under conditions of normal use and care. However, this fabric warranty does not cover crocking, shrinkage, piling or fading or where there is evidence of heavy soiling. Fabric damage or failure due to chemical treatment or improper cleaning is also excluded from warranty.

MECHANISMS ADULT RECLINERS

LIMITED LIFETIME WARRANTY

Manufacturer's limited lifetime warranty covers the repair of the patented parts of the reclining mechanism against manufacturing and material defects for the usual life of the product by the original consumer when use in a normal manner so long as patented parts are available. Manufacturer's obligation under this warranty is limited to repairing or replacing, at Manufacturer's option any part of the reclining mechanism found to be defective in material or workmanship upon examination by the manufacturer or representative. Costs for packing and shipping to and from the factory, if necessary, are not covered by the warranty.

HARDWOOD ROCKING CHAIRS

LIMITED ONE YEAR WARRANTY

WARRANTY TERMS: 1 Year on Construction 6 Months on Finish

What Is Covered: This product is covered under our manufacturer's Hinkle Chair Company 1 Year Limited Warranty. To ensure your complete satisfaction, this warrants to the original purchaser that this furniture is free from defects in material and workmanship as of the date of purchase and that it will, under normal use and proper care, remain so for 1 year after the date of purchase. The finish on this furniture is warranted for 6 months if furniture is used indoors or under a covered porch. Replacement of missing or initially defective parts will be sent at no charge for a period of 10 days from date of purchase. Hinkle Chair Company will not be responsible for missing parts and/or hardware after 10 days from date of purchase.

What Is Not Covered: Freight and packaging charges to and from our customer service center remain the customer's responsibility. Labor or material charges to remove or replace parts are not covered under this warranty. Any floor sample sales or clearance sales from the store are not covered by this warranty. Furniture used for commercial purposes; failures caused by improper care; unreasonable or abusive use; damage by modification or alteration; freeze damage; acts of God; rust; fabric stains; ripping or fading; purchased parts; or return freight and packaging charges are not covered under this warranty. Weathering will occur to any furniture product that is exposed to the elements for any significant time. Weathering is not covered under the finish warranty. These furniture products have a 200 pound weight capacity. It is not safe to exceed this maximum capacity and damage cause by exceeding this capacity is not warranted. Proof of purchase (dated register receipt) is required for warranty claims.



800-853-6625
www.blssports.com

1309 Raleigh Avenue
Norfolk VA 23507

PO Box 5329
High Point NC 27262

MATTRESS AND FOUNDATION LIMITED WARRANTY

Your mattress and matching foundation have been engineered to provide one of the finest sleep systems available. If, however, you discover a defect in your mattress or foundation, you should contact the retail store where you purchased your sleep set. If a defect occurs during the warranty period, Manufacturer shall, at its discretion, repair or replace your mattress or foundation after a complete inspection and determination that the damage is a result of a manufacturing defect during normal use. In the event of replacement, if identical materials are not available, Manufacturer may substitute material of comparable value or provide a refund. In order for this limited warranty to be valid, you must:

1. Be the original consumer purchaser;
2. Have purchased the sleep set from one of our authorized dealers;
3. Provide copy of the original store receipt, or other proof of purchase date, place of purchase and purchase price; and
4. Provide the law label affixed to the defective product.

You will be responsible for transportation costs of the product to and from the store or factory, as applicable.

ANY AND ALL IMPLIED WARRANTIES ON YOUR PRODUCT, INCLUDING ANY IMPLIED WARRANTY OF MERCHANTABILITY OR FITNESS FOR A PARTICULAR PURPOSE, SHALL NOT EXCEED IN DURATION THE TERM OF OF THIS LIMITED WARRANTY, WHICH BEGINS WITH THE DATE OF PURCHASE BY THE CONSUMER. THE SERVICE TERMS STATED IN THIS WARRANTY SHALL BE THE CONSUMER'S SOLE AND EXCLUSIVE REMEDY IN THE EVENT OF PRODUCT FAILURE DURING THE WARRANTY PERIOD. MANUFACTURER SHALL NOT BE LIABLE FOR INCIDENTAL OR CONSEQUENTIAL DAMAGES ARISING OUT OF THE USE OF THIS PRODUCT OR INABILITY TO USE THIS PRODUCT, OR FOR THE BREACH OF THIS OR ANY OTHER EXPRESS OR IMPLIED WARRANTY. MANUFACTURER DOES NOT WARRANT THAT THIS PRODUCT IS SUITABLE FOR ANY PERSON'S MEDICAL CONDITION. MANUFACTURER MAKES NO WARRANTY BEYOND WHAT IS CONTAINED IN WRITING.

Some states do not allow limitations on how long an implied warranty lasts, so this limitation may not apply to you. Some states do not allow the exclusion or limitation of incidental or consequential damages, so the above limitation or exclusion may not apply to you. This warranty gives you specific legal rights, and you may also have other rights, which vary from state to state. Manufacturer does not authorize any person to create for it any other obligation or liability in connection with this warranty.

Your warranty protects you from your date of purchase for the number of years shown in the LIMITED WARRANTY TIMETABLE (see below). In the event we repair or replace your sleep set, this warranty shall continue from your original purchase date. To find the limited warranty period that applies to your sleep system, see the two letter code shown on the tag law affixed to your Manufacturer mattress.

Manufacturer reserves the right to refuse service and invalidate this warranty when, upon inspection, the sleep set is found to be in an unsanitary condition or when the failure is due to causes other than defective workmanship or materials. Your warranty will not cover the following:

1. Structural damage from using an improper bed frame. This warranty applies to Queen or King size mattresses or foundations only if they are supported by an appropriate frame with a rigid center support having at least 5 legs or 5 hardwood (1" X 4") cross slats. See below for examples of proper bed frames for Queen and King mattress sets.

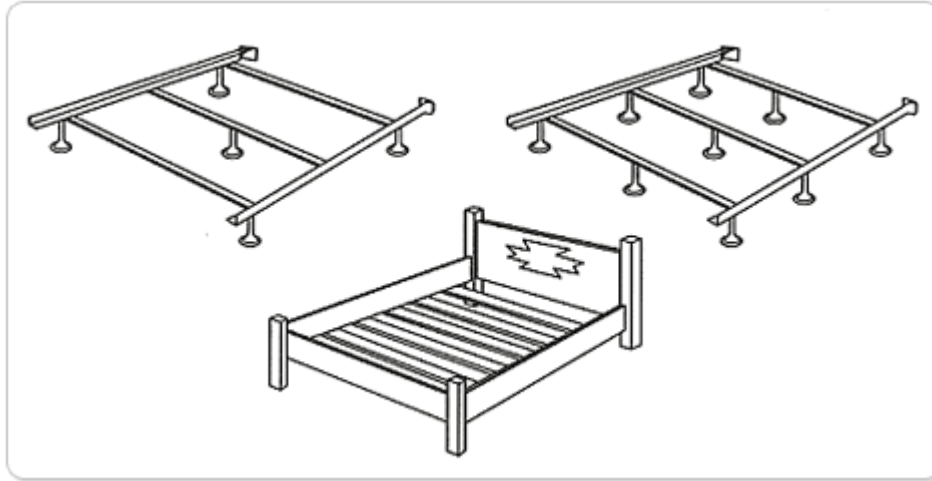

2. Structural damage to mattress not used in conjunction with a matching foundation, or equivalent, and an appropriate frame.
3. Mattress or foundation with burned, stained or soiled fabric.
4. Mattress or foundation damage due to abuse.
5. Mattress or foundation damage caused by moving or bending the sleep set.
6. Comfort preference.
7. Removal of law tag.
8. Body impressions less than 1.5" (A body impression less than 1.5" in any sleeping area is not considered a defect. Body impressions are caused by the natural compression and settling of quality upholstery materials. They are simply an indication that the upholstery layers are conforming to your body's individual contours).
9. Floor models and bedding sold "AS-IS".
10. Replacement of another piece in the sleep set, unless the other piece is also defective.
11. Handles and Corner Guards.

LIMITED WARRANTY TIME TABLE

CODE	TYPE OF LIMITED WARRANTY	BASE PERIOD LIMITED WARRANTY	PRO RATA REPAIR OR REPLACEMENT
MQ	20 Year	20 Year	20 Year
MP	15 Year	15 Year	15 Year
MO	10/20 Year	10 Year	10 Year
MN	10 Year	10 Year	10 Year
M5	5/15 Year	5 Year	10 Year
MM	5/10 Year	5 Year	5 Year
ML	3/10 Year	3 Year	7 Year
MK	1/10 Year	1 Year	9 Year
MJ	1/5 Year	1 Year	4 Year
MI	1/3 Year	1 Year	3 Year
MH	1/1 Year	1 Year	1 Year
NW	0 Year	0 Year	0 Year